

NP3001

10MHz Frequency Reference with AutoCAL, OCXO, GNSS, PPS and NMEA simulator with Master PPS/NMEA Input, and Programmable Priority Levels



All information provided herein is the proprietary property of Novus Power Products L.L.C. The information included may be reproduced without the permission or prior approval of Novus Power Products L.L.C. for the purpose of operating the Novus equipment.

WARNING!

THIS DEVICE IS FOR LAB AND SIMULATION USE ONLY. THIS DEVICE IS NEITHER INTENDED NOR CERTIFIED FOR USE IN MARINE OR AVIATION NAVIGATION.

DANGER!

THIS DEVICE IS DESIGNED TO PRODUCE SIMULATED GPS DATA MARKED "VALID" WHICH MAY BE FALSE OR LACKING CONTINUITY. NEVER USE FOR NAVIGATION OR SAFETY CRITICAL APPLICATIONS.

CAUTION!

THIS DEVICE GENERATES A SIMULATED PPS SIGNAL WHICH MAY BE NON CONTINUOUS OR ABSENT UNDER NORMAL OPERATION. DO NOT USE FOR TIMING CRITICAL FUNCTIONS.

DANGER!

UNDER NORMAL OPERATION, THIS DEVICE PROVIDES GPS NMEA DATA THAT WILL BE DELAYED BY AT LEAST ONE SECOND. NEVER USE THIS DEVICE FOR NAVIGATION OR SAFETY CRITICAL APPLICATIONS.

	User Manual	NP3001-OG
	Revision #:	G
	Date:	11-14-17

Contents

1.0 Summary	4
2.0 Controls and Indicators	5
2.1 Front Panel	5
2.1.1 Status Display - OLED	5
2.1.2 Status Buttons	7
2.2 Rear Panel	8
2.2.1 PPS Output:	8
2.2.2 Master PPS Input:	8
2.2.3 10 MHz Output	9
2.2.4 Power Input / Status Relay	9
2.2.5 NMEA RS-232 port (DB9 Female)	10
2.2.6 Master Input RS-232 port (DB9 Male)	11
4.0 Functional Description	12
4.1 Programming Setup Description	13
5.0 Typical Phase Noise	14
6.0 Built-in Test	14
7.0 Power Supplies	14
8.0 GNSS Function	14
9.0 Programming Guide	16
9.1 Commands	17
9.2 Proprietary NMEA Status String	21
10.0 Mechanical	22
11.0 Specifications	24
12.0 Limited Hardware Warranty	25

	User Manual	NP3001-OG
	Revision #:	G
	Date:	11-14-17

1.0 Summary

The NP3001-O/G is a GNSS locked 10 MHz frequency reference with auto-calibration. Distinguishing features of this reference include a PPS simulator based on the internal high-performance OCXO. A NMEA simulator provides NMEA data in the absence of any GPS lock or antenna, but also allows GPS locked NMEA data or a third Master NMEA data source to override the internal simulator.

10 MHz: The internal source is a GNSS disciplined OCXO, actively controlled by a mixed-signal phase lock loop. The 10 MHz sine output is sourced from an intrinsically low jitter voltage-controlled crystal oscillator.

PPS: The NP3001-O/G is capable of providing a GPS locked PPS, and a simulated PPS based on the OCXO in the absence of GPS lock. If no GPS signal is needed, the unit acts as a PPS source, 10 MHz source, and NMEA simulator.

NMEA Simulator: The onboard NMEA simulator provides an OCXO based PPS aligned NMEA signal, with or without GPS/GNSS access. Priority of signals can be programmed so that the simulator can function on its own, producing usable NMEA data until GPS lock is achieved, or a Master input is present. Either the Master input or the GPS input can override the simulator, based on programmable values. These values can be set by serial port RS-232 connection.

The NMEA simulator will continue to produce NMEA data when one or either of the overriding sources has been lost. For example, if GPS lock is lost, the NMEA simulator will continue to produce PPS and NMEA with no intervention required.

Self Test: The NP3001-O/G continually monitors temperature and aging such that, when the unit goes into holdover or loses GNSS lock, the output frequency reverts at the last known locked frequency value. The calibration feature continually monitors the correction coefficients developed through GNSS timing information. These are sampled multiple times per day and stored in non-volatile memory and in the event of a GNSS loss, the saved coefficients are applied to the OCXO. This effectively eliminates long-term crystal drift.

There is an extensive built-in test loop that drives an OLED display and relay contacts for system integration. Relays offer the ability to remotely monitor for fault or loss of GNSS lock. There is also a GNSS lock status signal (and LED), PPS and a serial port to provide access to NMEA time stamp data. The NP3001-O/G can operate from DC power from -60 VDC to +60 VDC in three ranges. A power converter provides electrical isolation from the power source to the output (configuration option).

All inputs and outputs are electrostatic discharge protected. Any output can be shorted indefinitely with no permanent damage to the unit.

	User Manual	NP3001-OG
	Revision #:	G
	Date:	11-14-17

2.0 Controls and Indicators

2.1 Front Panel

2.1.1 Status Display - OLED

The OLED display provides basic information to the user, and can be advanced by pressing the “NEXT” Button. The OLED display defaults to the output time string, followed by the PPS and NMEA data sources surrounded by parentheses (), in priority order. (2=Master, 1=GPS, 0=Sim). The current PPS discipline source is shown on the left (in its priority list, and the current NMEA source is shown on the right (in its priority list).

This display shows the user not only what the source of the data is, but also the priority settings, and where the current source resides in the priority list.

Example 1:



PPS Priority: 2,1,0 (Source = 0) / NMEA Source Priority: 2,1,0 (Source = 0)

This example shows that the data is provided from the Sim, and no valid source (as user defined) is present in either the GPS or Master input.

Example 2:



PPS Priority: 2,1,0 (Source = 1) / NMEA Source Priority: 2,1,0 (Source = 1)

This example shows the GPS providing NMEA and PPS, overriding the simulator due to the priority settings. However, no Master is present even though Master input is prioritized.

	User Manual	NP3001-OG
	Revision #:	G
	Date:	11-14-17

Example 3:



PPS Priority: 2,0,1 (Source = 0) / NMEA Source Priority: 2,0,1 (Source = 2)

This example shows the Master input as the only priority override for the simulator. In this case, the user would use a Master input, discipline the unit, without interruption from the GPS. The PPS display indicates there is no PPS present to discipline the simulator.

GPS and MASTER input status Screen:

This screen indicates whether the provided NMEA strings indicate validity (Locked), or not (Track). Number of GPS satellites in view is provided to show progress of lock.



PPS Mode Screen:

The PPS Mode screen allows the user to toggle the PPS Output source between the GPS Receiver and the OCXO based holdover PPS. During GPS/GNSS sourcing, the PPS will deviate <30ns rms while the receiver is locked. When the receiver is not GPS locked, PPS is not present by default.

Since the OCXO PPS disciplines to the GPS receiver, the OCXO mode can be used when GPS/GNSS lock is lost, keeping the PPS within the drift performance of the OCXO.



	User Manual	NP3001-OG
	Revision #:	G
	Date:	11-14-17

NMEA Source Screen:

The NMEA Source screen allows the user to toggle access directly between the GPS/GNSS receiver or the simulated NMEA output.

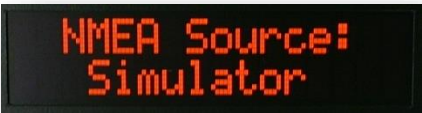

Warning: NMEA Source: GPS/GNSS will disconnect access to control commands, and allow direct access to the internal GPS receiver. When the selected NMEA Source is the GPS/GNSS receiver, the user can communicate directly with the GPS/GNSS module. When the selected NMEA source is the simulator, the user can access all the commands in the programming guide. Direct access to the receiver is provided for those who need direct radio access for setup. Recommended to leave as NMEA Source: Simulator.

Battery Status:

The remaining percentage of battery life is displayed, providing the user an indication of need to recharge. Recharging takes place any time power is provided to the 12V power input, and is managed by an IC to prevent overcharging. The percentage value from the display is not accurate while power is connected.

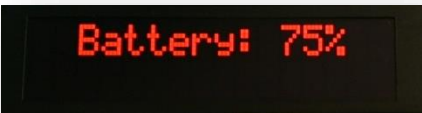

If the battery indicator falls below 5%, an indicator will flash on the main screen to notify the user.

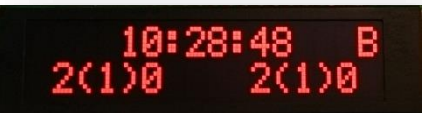

2.1.2 Status Buttons

There are two status buttons. The top button "NEXT" will toggle the display menus. The lower button is reserved for future use.

2.2 Rear Panel

2.2.1 PPS Output:

The OCXO based PPS is the default PPS output upon system start. PPS will automatically be available for simulation with no input from GPS locked source or Master input. If/when GPS achieves lock, or Master input signal is provided, priority will switch to these sources for the PPS if defined by the user. This feature can be prioritized in any order, or disabled.

The PPS output prioritization scheme will be dependent on the presence of a signal at the given priority. If the priority of the PPS is MASTER, then GPS, followed by the SIM, the output will be from the GPS if the MASTER PPS has not been present for a defined age out period (default is 1s + 10ms). If neither the MASTER or the GPS PPS are present, the output will be from the OCXO PPS.

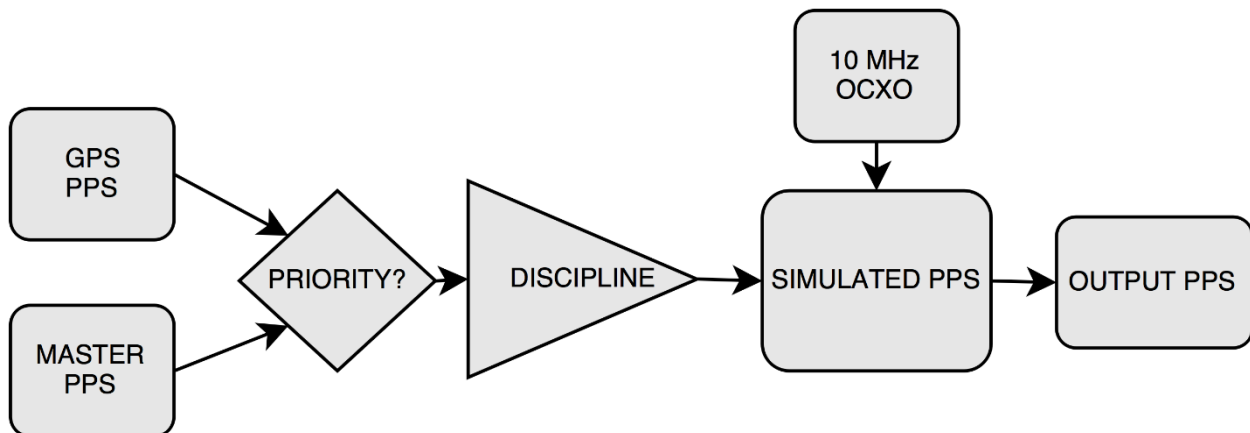

2.2.2 Master PPS Input:

If available, a master PPS source can be provided to sync the PPS output, and NMEA simulated output. If prioritized, this signal can override the simulated signal, the GPS signal, or neither.

Example 1: Master input provides a synchronized PPS signal on startup, and, when GPS lock is achieved, the PPS and NMEA input are overridden and output is based on the internal GPS locked source.

Example 2: Master input is provided, but until NMEA is valid or PPS is present at master input, the PPS and NMEA output are based on the internal simulator.

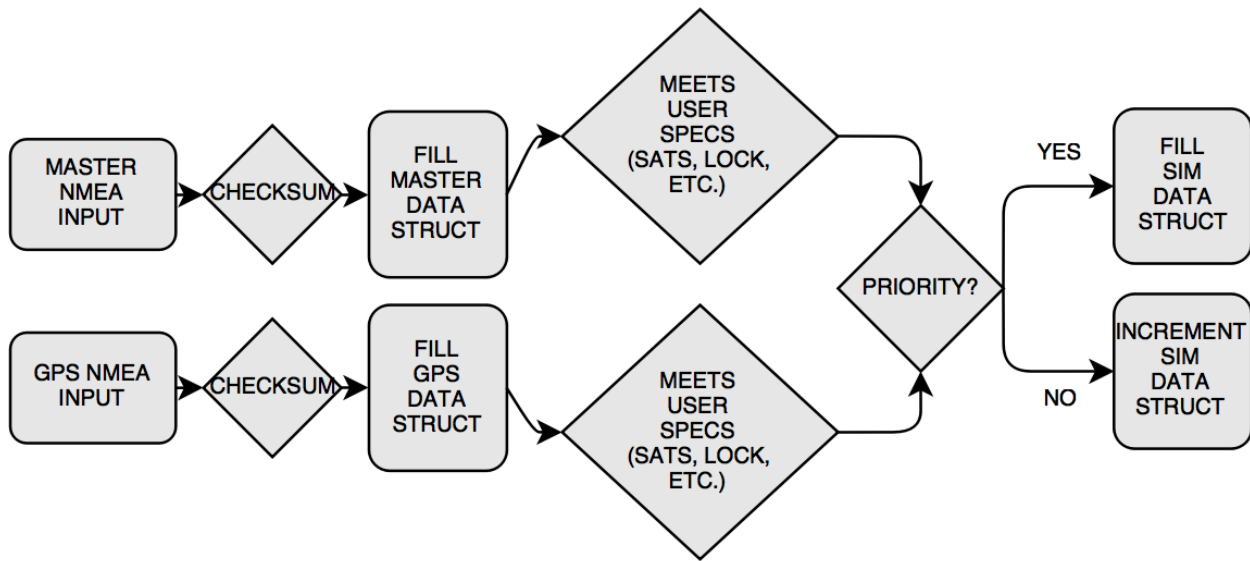

Figure 1. User can set priority levels to automatically provide PPS and NMEA from available source. If neither GPS nor master is available. NMEA and PPS will be generated by simulator.

2.2.3 10 MHz Output

The 10 MHz source is provided at this output. Sine output 1Vrms.

Optional: CMOS output 3.3Vpp or 5Vpp.

2.2.4 Power Input / Status Relay

A 4-pin Phoenix connector handles the 12Vdc input, as well as a relay indicator. The relay is closed during normal operation, and can be used to monitor a fault condition. The relay contacts are rated at 20VDC or AC 0.5 amps, and are floating. This connector provides power input for operation as well as battery recharging.

Pinout (4 position Terminal Block - On Shore Tech OSTTJ0411530)

Pin 1 – GND

Pin 2 – 12Vdc

Pin 3 – Status Relay (+)

Pin 4 – Status Relay (-)

.2.5 NMEA RS-232 port (DB9 Female)

The RS-232 port (socket) provides the main NMEA data output, as well as input of command variables and flash settings.

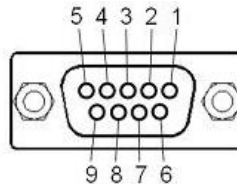

Female DB-9

Pin	Function	I/O
1	NC	
2	NMEA port / Command Port TX	O
3	NMEA Port / Command Port RX	I
4	NC	
5	GND	
6	NC	
7	NC	
8	NC	
9	NC	

Note: Routing the PPS through the DB9 is offered as an option that might ease system integration.

2.2.6 Master Input RS-232 port (DB9 Male)

The Master input RS-232 port allows input of NMEA data for synchronization of simulator with input data.

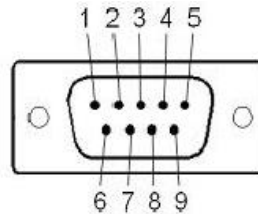

Male DB-9

Pin	Function	I/O
1	NC	
2	NMEA port / Command Port RX	I
3	NMEA Port / Command Port TX	O
4	NC	
5	GND	
6	NC	
7	NC	
8	NC	
9	NC	

4.0 Functional Description

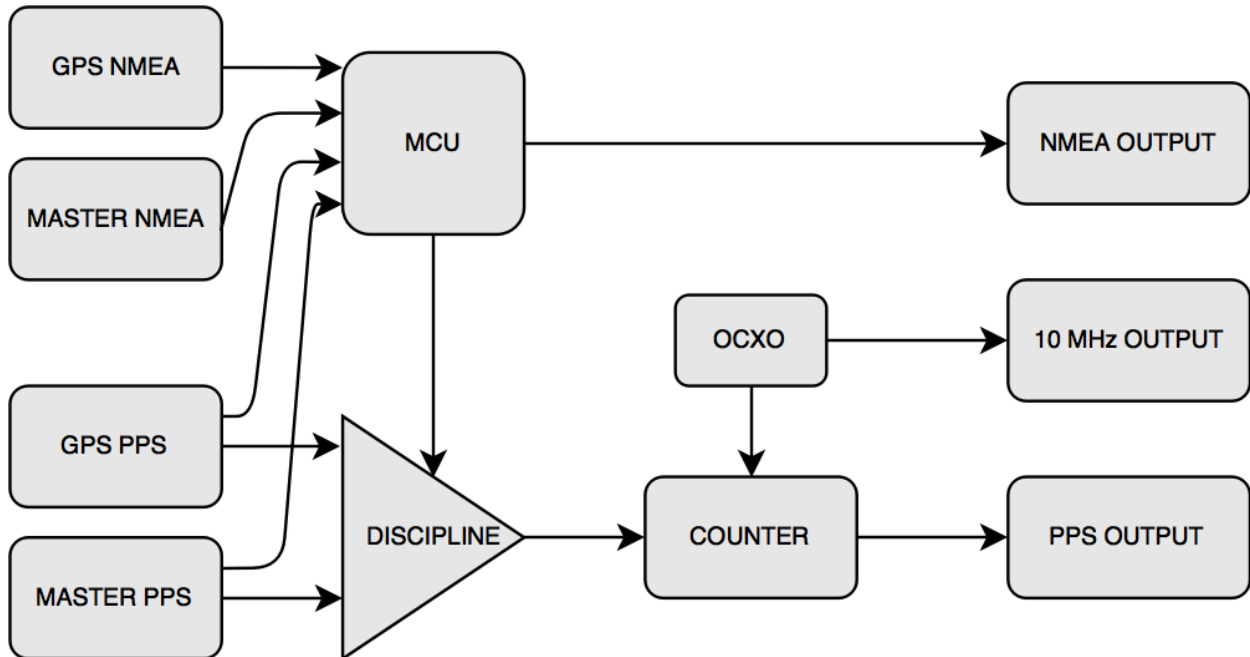

4.1 Programming Setup Description

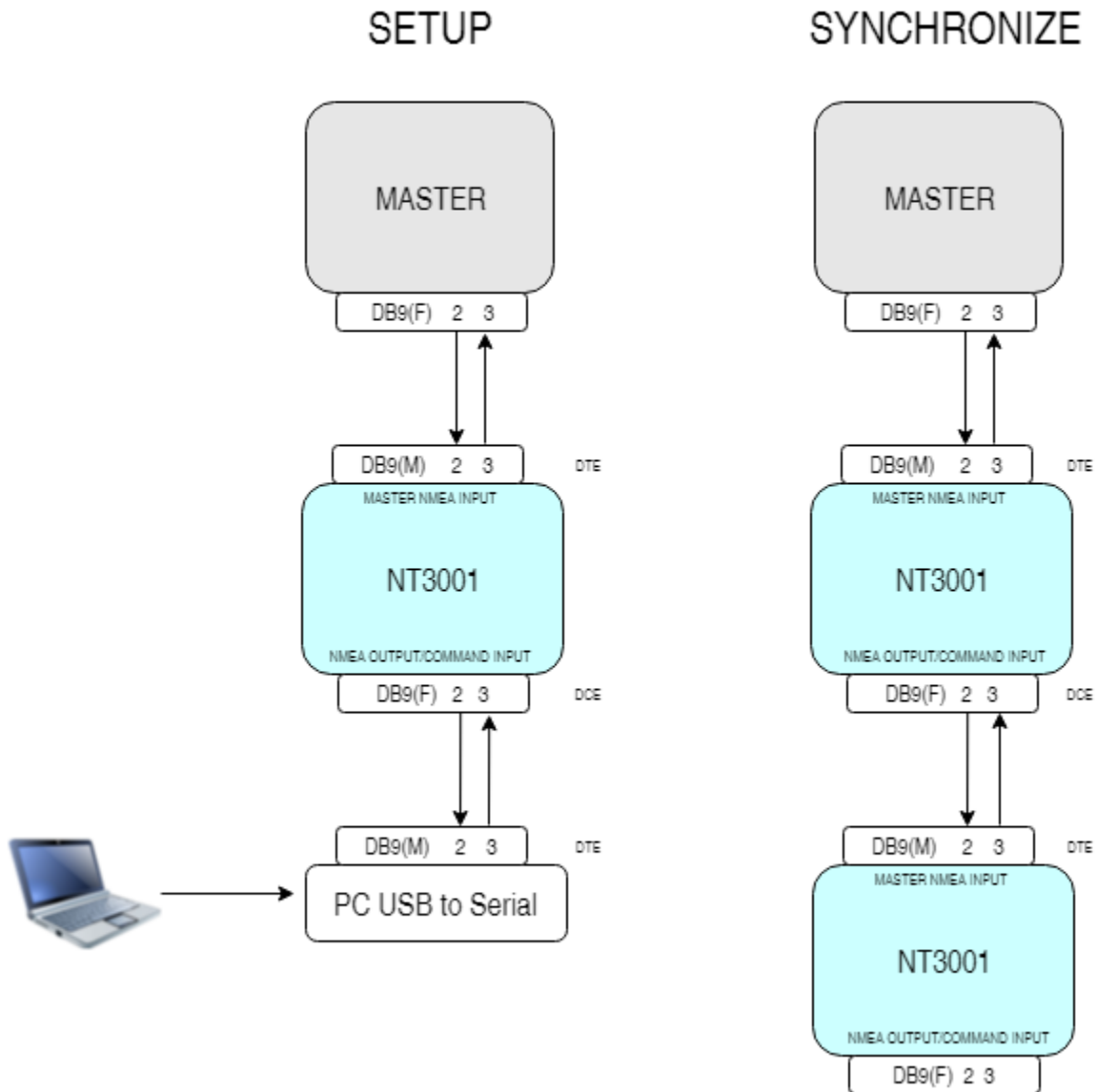

	User Manual	NP3001-OG
	Revision #:	G
	Date:	11-14-17

5.0 Typical Phase Noise

10MHz Sine - Primary Output

Offset Frequency (Hz)	Typical (dBc / Hz)
10	-102
100	-110
1K	-124
10K	-133

There are additional optional phase noise performance levels available – please contact the factory for more information.

Low phase noise contribution is achieved through careful PCB design, component selection and minimization of power supply noise.

6.0 Built-in Test

There are number of power supplies in the design to meet special needs and noise reduction. Each supply is monitored and a power failure will open the status relay.

7.0 Power Supplies

The standard unit is designed to operate from a nominal 12 VDC. However, the unit can be operated from 110 VAC to 250VAC and/or -60 to +60 VDC. A power adapter is available that provides 12 VDC from standard AC power. The unit can also be provided to operate from - 60 to +60 VDC in three ranges. Contact the factory to define this requirement.

8.0 GNSS Function

The receiver needs to be able to see at least four satellite vehicles (SVs) to obtain an accurate 3-D position fix. When travelling in a valley, built-up area or under heavy tree cover, you will experience difficulty acquiring and maintaining a coherent satellite lock.

Complete satellite lock may be lost, or only enough satellites (3) tracked to be able to compute a 2-D position fix, or a poor 3D fix due to insufficient satellite geometry (i.e. poor DOP). Inside a

	User Manual	NP3001-OG
	Revision #:	G
	Date:	11-14-17

building or beneath a bridge, it may not be possible to update a position fix. The receiver can operate in 2-D mode if it goes down to seeing only 3 satellites by assuming its height remains constant. But this assumption can lead to very large errors, especially when a change in height does occur. A 2-D position fix is not considered a good or accurate fix; it is simply “better than nothing”.

The receiver’s antenna must have a clear view of the sky to acquire satellite lock. Remember, it is the location of the antenna that will be given as the position fix. If the antenna is mounted on a vehicle, survey pole, or backpack, allowance for this must be made when using the solution.

To measure the range from the satellite to the receiver, two criteria are required: signal transmission time and signal reception time. All GNSS satellites have several atomic clocks that keep precise time and are used to time-tag the message (i.e. code the transmission time onto the signal) and to control the transmission sequence of the coded signal. The receiver has an internal clock to precisely identify the arrival time of the signal. Transit speed of the signal is a known constant (the speed of light), therefore: $\text{time} \times \text{speed of light} = \text{distance}$.

Once the receiver calculates the range to a satellite, it knows that it lies somewhere on an imaginary sphere whose radius is equal to this range. If a second satellite is then found, a second sphere can again be calculated from this range information. The receiver will now know that it lies somewhere on the circle of points produced where these two spheres intersect.

When a third satellite is detected and a range determined, a third sphere intersects the area formed by the other two. This intersection occurs at just two points. A fourth satellite is then used to synchronize the receiver clock to the satellite clocks.

In practice, just four satellite measurements are sufficient for the receiver to determine a position, as one of the two points will be totally unreasonable (possibly many kilometers out into space). This assumes the satellite and receiver timing to be identical. In reality, when the receiver compares the incoming signal with its own internal copy of the code and clock, the two will no longer be synchronized. Timing error in the satellite clocks, the receiver, and other anomalies, mean that the measurement of the signal transit time is in error.

This, effectively, is a constant for all satellites since each measurement is made simultaneously on parallel tracking channels. Because of this, the resulting ranges calculated are known as “pseudo-ranges”.

To overcome these errors, the receiver then matches or “skews” its own code to become synchronous with the satellite signal. This is repeated for all satellites in turn, thus measuring the relative transit times of individual signals. By accurately knowing all satellite positions, and measuring the signal transit times, the user’s position can be accurately determined.

This LED illuminates green when the unit is locked to the GNSS system. If the LED is flashing green, the unit is operating on the OCXO and is attempting to gain GNSS Lock.

If the GNSS indicator remains flashing green for an extended period of time, it could be an indication of an antenna, cabling or unit malfunction. Confirm the antenna is still connected and

	User Manual	NP3001-OG
	Revision #:	G
	Date:	11-14-17

has not become obstructed from a clear view of the sky. To check the unit, an alternate antenna can be tried in order to isolate the malfunction. For further support, please contact the factory at 866-313-9401.

There is free software that can be downloaded from www.synreference.com that will allow baud rate changes, cable compensation and other features.

9.0 Programming Guide

The NP3001-OG can accept user commands which will provide particular performance which may be customized. The priority of NMEA source input, PPS source input, and many parameters can be adjusted by the user, and saved in non-volatile flash memory.

If the user makes several changes which are intended to be kept between power off cycles, the command "SAVEFLASH<CR><LF>" will update flash to reflect all current settings.

Table 1 shows a complete list of input commands and descriptions. As a general rule, a command can be input without "=" or additional value, and the unit will respond with the current setting's value. If the input is not understood, the microcontroller will return the value "?<CR><LF>"

NOTE: All commands should be followed by <cr><lf>.

9.1 Commands

Setting	Command	Response	Description
PPS PRIORITY	#PRIO<cr><lf>	#PRIORITY=<current priority><cr><lf>	Query current PPS source priority
	#PRIO=0,X,X		Accepts "0", "1", or "2" in a comma separated series. Will accept any combination of 0,1,2. Example: Assigns PPS priority to OCXO PPS simulator only.
	#PRIO=1,2,0		Example: Assigns PPS priority to GPS receiver. If present, GPS PPS is output, else Master PPS is output, else SIM.
	#PRIO=2,1,0		Example: Assign PPS priority to Master PPS input. If present, Master PPS is output, else GPS PPS is output, else SIM.
NMEA DATA SIMULATION OVERRIDE PRIORITY	#OVRR<cr><lf>	OVRRDSIM=<current sim override>	Query current NMEA Sim override priority.
	#OVRR=0,X,X		Accepts "0", "1", or "2" in a comma separated series. Will accept any combination of 0,1,2. Example: Assigns NMEA priority to simulator. No override.
	#OVRR=1,2,0		Example: Assigns NMEA priority to GPS then MASTER. When GPS NMEA is valid, or otherwise indicated, GPS NMEA will override, then Master, then SIM.
	#OVRR=2,1,0		Example: Assigns NMEA priority to MASTER then GPS. When MASTER NMEA is valid, or otherwise indicated, MASTER NMEA will override, then GPS, then SIM.
MASTER INPUT BAUD RATE	#BAUDMS	#BAUDNM=<current Baud Rate>	Query Baud Rate on Master NMEA Input. (Default = 38400)
	#BAUDMS=38400		Assign Baud rate to Master NMEA Input. (4800, 9600, 19200, 38400, 57600, or 115200)
NMEA OUTPUT BAUD RATE	#BAUDNM	#BAUDNM=<current Baud Rate>	Query Baud Rate on NMEA output. (Default = 38400)
	#BAUDNM=38400		Assign Baud rate to NMEA output. (4800, 9600, 19200, 38400, 57600, or 115200) Note: Baud Rates below 19200 will automatically shut off GSV, GLL, and GNS string output. This is required to meet the maximum character output during one second.



User Manual	NP3001-OG
Revision #:	G
Date:	11-14-17

ALLOW UNLOCKED GPS TO OVERRIDE	#UNLGPS	#UNLNME=<current setting>	Allow NMEA data from unlocked internal GPS source to override NMEA simulation when minimum satellite number is present. Enable = 1 , Disable = 0 (Default)
	#UNLGPS=0		
ALLOW UNLOCKED MASTER TO OVERRIDE	#UNLMST	#UNLMST=<current setting>	Allow NMEA data from unlocked MASTER source to override NMEA simulation when minimum satellite number is present. Enable = 1 , Disable = 0 (Default)
	#UNLMST=0		
MINIMUM GPS SATELLITES FOR OVERRIDE	#SATMINGPS	#SATMINGPS=<current setting>	Set the minimum number of satellites needed to override NMEA simulation from GPS source (Default = 3). This will allow NMEA data to be sourced from GPS when waiting for lock, even though lock has not been achieved.
	#SATMINGPS=3		
MINIMUM MASTER SATELLITES FOR OVERRIDE	#SATMINMST	#SATMINMST=<current setting>	Set the minimum number of satellites needed to override NMEA simulation from MASTER source (Default = 3). This will allow NMEA data to be sourced from MASTER when waiting for lock, even though lock has not been achieved.
	#SATMINMST=3		
FORCE VALID MARKER DURING SIMULATION	#SIMVALID	#SIMVALID=<current setting>	Force NMEA strings to indicate "Valid" or "Locked" (RMC, GGA, GLL, GNS, GSA) even when no valid source is present. If disabled, strings will still indicate "Valid" or "Locked" when source provides valid signal. Enable = 1 , Disable = 0 (Default = 0)
	#SIMVALID		
GSV STRING HOLDOVER	#HOLDGSV	#HOLDGSV=<current setting>	If enabled, GSV strings from last valid source will be repeated after loss of signal or lock. If disabled, GSV strings will only be provided if present from the valid sources. Enable = 1 , Disable = 0 (Default = 0)
	#HOLDGSV=1		
REQUIRE GPS PPS FOR STRING VALIDITY	#RPGPS	#RPGPS=<current setting>	If enabled, requires presence of PPS from GPS receiver before GPS NMEA string is recognized as valid. Enable = 1, Disable = 0 (Default = 0)
	#RPGPS=0		
REQUIRE MASTER PPS FOR STRING VALIDITY	#RPMST	#RPMST=<current setting>	If enabled, requires presence of PPS from Master Input before Master NMEA string is recognized as valid. Enable = 1, Disable = 0 (Default = 0)
	#RPMST=0		
SET TIME	#TIME	#TIME=<current time setting>	Simulation TIME can be set, and, until override, will increment with PPS. The time must be entered in 24 hour format (hhmmss). Example: <#TIME=133050> will change the simulated output to
	#TIME=hhmmss		

			13:30:50. Note: Use "OFFSET" to change overall timing or to adjust timezone. Setting "TIME" is a convenient and quick method for simulations, will change the simulator only, and will remain valid until overwritten.
CHANGE GMT OFFSET	#OFFSET	#OFFSET=<current setting>	GMT offset can be changed to reflect user's timezone or desired value by setting the difference from UTC. The offset must be written in an hours minutes format (±hhmm). Default setting is +0000. Values entered cannot exceed ±1300. Example: <#OFFSET=-0430> would change the NMEA data timing to GMT - 04:30. M
	#OFFSET=±hhmm		
INCREMENT INCOMING MASTER NMEA DATA	#INCMST	#INCMST=<current setting>	Increments the incoming MASTER NMEA data by one second for the next outgoing NMEA string. Enable = 1, Disable = 0 (Default = 1)
	#INCMST=1		
INCREMENT GPS NMEA DATA	#INCGPS	#INCGPS=<current setting>	Increments the internal GPS NMEA data by one second for the next outgoing NMEA string. Enable = 1, Disable = 0 (Default = 0)
	#INCGPS=0		
RMC OUTPUT	#RMC	#RMC=<current RMC output frequency>	Query RMC String output Frequency. (Default = 1)
	#RMC=1		Change RMC String output Frequency in seconds. (0-60)
GGA OUTPUT	#GGA	#GGA=<current RMC output frequency>	Query GGA String output Frequency. (Default = 1)
	#GGA=1		Change GGA String output Frequency in seconds. (0-60)
GLL OUTPUT	#GLL	#GLL=<current RMC output frequency>	Query GLL String output Frequency. (Default = 1)
	#GLL=1		Change GLL String output Frequency in seconds. (0-60)
ZDA OUTPUT	#ZDA	#ZDA=<current RMC output frequency>	Query ZDA String output Frequency. (Default = 1)
	#ZDA=1		Change ZDA String output Frequency in seconds. (0-60)
GNS OUTPUT	#GNS	#GNS=<current RMC output frequency>	Query GNS String output Frequency. (Default = 1)
	#GNS=1		Change GNS String output Frequency in seconds. (0-60)
GSV OUTPUT	#GSV	#GSV=<current RMC output frequency>	Query GSV String output Frequency. (Default = 1)
	#GSV=1		Change GSV String output Frequency in seconds. (0-60)
NVS OUTPUT	#NVS	#NVS=<current RMC output frequency>	Query NVS String output Frequency. (Default = 1)

	#NVS=1		Change NVS String output Frequency in seconds. (0-60)
ALL STRINGS OUTPUT	#ALL=1	#ALL=1	Change ALL String output Frequencies in seconds. (0-60). Note this is a convenient way to set all string frequencies at once, usually back to 1Hz. Setting ALL=0 will shut off all NMEA string output. Any other setting will affect all NMEA strings at once.
PPS AGE OUT	#AGEOUT #AGEOUT=1010	#AGEOUT=<current PPS ageout>	Accepts values from 1000 to 1100ms. This is the ageout period (in ms) for one PPS source to provide a signal before switching to the next priority. (Default = 1010)
DEFAULT LEAP SECOND	#DEFLS=17	#DEFLS=<current DEFLS>	Adjust default leap second. Accepts values between 0-32. (Default = 17) To update default leap second, change the value using the DEFLS=<value> command, then save to flash. A restart of the unit is required for the DEFLS update to take effect.
SAVE ALL VALUES TO FLASH MEMORY	#SAVEFLASH	#SAVED TO FLASH. #FLASH SAVE FAILED.	This command will translate all current variables to flash string and write. Data is then read back for verification, and result reported.
RESET ALL TO DEFAULT	#RESETALL	#RESET FLASH VARIABLES.	Resets all user settings to default values and overwrites flash memory with defaults.
INVALID INPUT		#?	Command not recognized.

	User Manual	NP3001-OG
	Revision #:	G
	Date:	11-14-17

9.2 Proprietary NMEA Status String

\$GPNVS	hhmmss	x	x	Px	Sx	Px	Px	Px	Vx	Vx	Vx	xx	*xx
1	2	3	4	5	6	7	8	9	10	11	12	13	14

<u>#</u>	<u>Description</u>	<u>Range</u>
1.	Identifier	\$GPNVS
2.	Time (UTC)	hhmmss
3.	GPS Lock (Valid)	"A" = Valid, "V" = Not Valid
4.	Master Lock (Valid)	"A" = Valid, "V" = Not Valid
5.	Current PPS Source	0 = SIM, 1 = GPS, 2 = MASTER
6.	Current NMEA Source	0 = SIM, 1 = GPS, 2 = MASTER
7.	PPS Priority 1st	0 = SIM, 1 = GPS, 2 = MASTER
8.	PPS Priority 2nd	0 = SIM, 1 = GPS, 2 = MASTER
9.	PPS Priority 3rd	0 = SIM, 1 = GPS, 2 = MASTER NMEA
10.	NMEA Override Priority 1st	0 = SIM, 1 = GPS, 2 = MASTER
11.	NMEA Override Priority 2nd	0 = SIM, 1 = GPS, 2 = MASTER
12.	NMEA Override Priority 3rd	0 = SIM, 1 = GPS, 2 = MASTER
13.	Hex error Message*	0x00 - 0xFF
14.	NMEA Checksum	*XX (xor'd value of bytes between \$ and *)

Example:

\$GPNVS,233518,A,V,P1,S1,P2,P1,P0,V2,V1,V0,00*1D

Time: 23:35:18; GPS locked; Master unlocked; PPS source: GPS; NMEA source: GPS; Priority = 2,1,0; NMEA Override = 2,1,0; Error Message = none; Checksum: 1D

*Hex error message is the OR'd value of any errors that have been recorded during operation.

<i>Error</i>	<i>Message</i>
0x01	Flash Loaded from defaults
0x02	Flash save failed
0x80	Battery is Low. Less than 5% remaining.

10.0 Mechanical

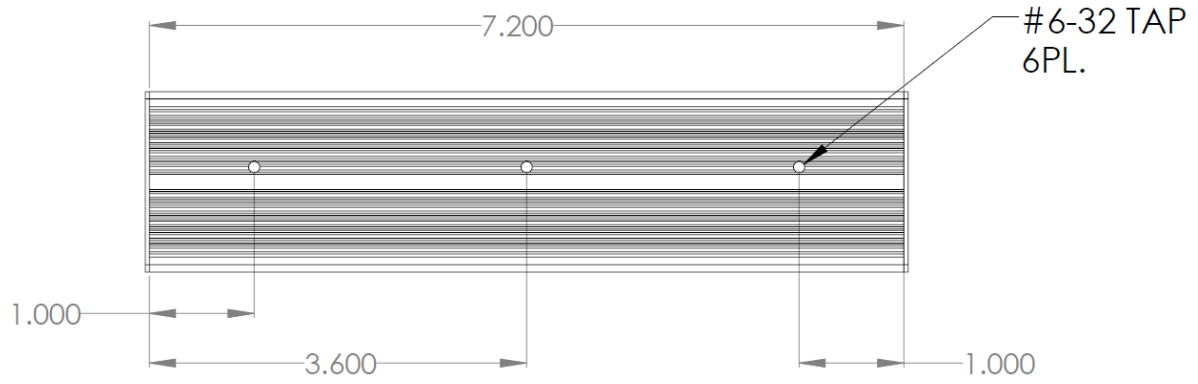

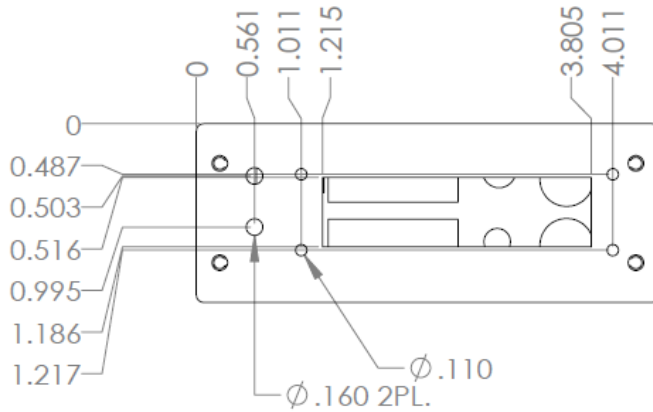

REAR VIEW IS ORIENTATED UPSIDE DOWN

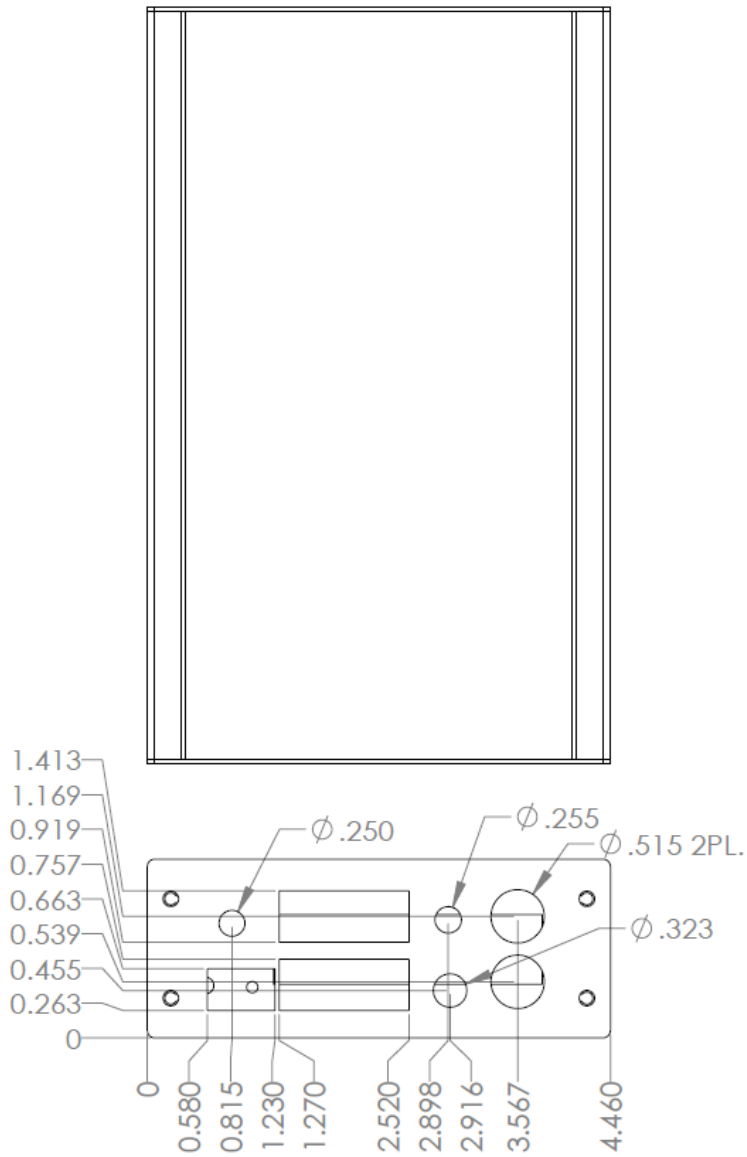

	User Manual	NP3001-OG
	Revision #:	G
	Date:	11-14-17

11.0 Specifications

10MHz Sine	1.0 Vrms, 50 Ohm - BNC
Harmonics	Less than -30 dBc
Locked Stability	<~E-11 after 100 seconds
First Year Frequency Stability	±50 ppb (long-term unlocked)
Temp Stability	±10 ppb
Yearly Aging	±30ppb
Receiver Sensitivity	-155dBm
PPS Locked GPS	30ns RMS accuracy, 3.3 Volt logic, output impedance CMOS (±20ma)
PPS Simulated	200ns RMS accuracy, 3.3 Volt logic, output impedance CMOS (±20ma)
PPS Output	3.3 Volt CMOS (30 ma drive), Pulse width 400 usec, Rise-Fall < 10 ns
PPS Input	3.3 Volt CMOS (Sync aligned to leading edge < 200ns)
NMEA Output	Full RS232 levels – NMEA-0183
NMEA Input	Full RS232 levels – NMEA-0183
2x16 OLED Display	UTC Time, Simulator Source, Priority
Battery	Lithium-Ion 4.7Ah
Power Requirements	9 to 15 VDC @ 1.0 amps max (<10 Watts)
Connectors - Front panel	BNC (2) - PPS input/output
	SMA – 10 MHz Sine
	DB9 Male – RS232 NMEA Input
	DB9 Female – RS232 NMEA Output
Power connector	Power Terminal (4 Pin) - OSTTJ0411530
Operating Temperature	0 to 50°C non-condensing (extended temperature range available)
Storage Temperature	-40 to 70°C
Width	4.6"
Depth	7.2" (exclusive of connectors)
Height	1.8"
Weight	~16 oz.

	User Manual	NP3001-OG
	Revision #:	G
	Date:	11-14-17

12.0 Limited Hardware Warranty

Novus Power Products (hereinafter Novus) warrants its products to the original end user (“original purchaser”) and warranty is not transferable. Novus guarantees that the NOVUS hardware products that you have purchased from NOVUS are free from defects in materials or workmanship under normal use during the LIMITED WARRANTY PERIOD. The LIMITED WARRANTY PERIOD starts on the date of shipment and for the period of 1 (one) year to be free from defects caused by faulty materials or poor workmanship, provided:

- (a) NOVUS is notified in writing by Buyer of such defect prior to the expiration of the warranty period, and
- (b) after receiving return authorization –RMA- from NOVUS, the defective item is returned with transportation prepaid to NOVUS, Independence, Missouri, with transportation charges prepaid by Buyer ...see RMA policy in Terms and conditions, and
- (c) NOVUSs’ examination of such unit shall disclose to its satisfaction that such defect(s) exist and have not been caused by misuse, neglect, improper installation, improper storage, unauthorized modifications, inadequate maintenance, operation outside the environmental specifications for the product, repair alteration, or accident. NOVUS assumes no risk or liability for results of the use of products purchased from it, including but without limiting the generality of the foregoing: (1) the use in combination with any electrical or electronic components, circuits, systems, assemblies or any other materials or substances; (2) unsuitability of any product for use in any circuit or assembly. Removal or tampering with tamper-proof label on merchandise will void warranty coverage unless with the written authorization from NOVUS
- (d) an evaluation fee will be charged to Buyer to cover inspection and testing costs for any item returned by Buyer under this paragraph which is found to be within specifications and/or otherwise not the responsibility of NOVUS under the terms and conditions of this paragraph or any other part of this Agreement..

Your dated sales or delivery receipt is your proof of the purchase date. You may be required to provide proof of purchase as a condition of receiving warranty service. You are entitled to hardware warranty service according to the terms and conditions of this document if a repair to your NOVUS product is required during the limited warranty period. Our obligation at NOVUS is limited to repair or replace products which prove to be defective.

Should Novus be unable to repair or replace the product within a reasonable amount of time, the customer’s alternate remedy shall be a refund of the purchase price upon return of the product to Novus. The liability of NOVUS under this warranty is limited to replacing, repairing or issuing a credit, at its option, for any such item returned by Buyer under the terms of this warranty.

EXCLUSIONS: The above warranty shall not apply to defects resulting from improper or inadequate maintenance by the customer, customer-supplied software or interfacing, unauthorized modification or misuse, operation outside of the environmental specifications for the product or improper site preparation and maintenance (if applicable). For probes, cables, antennas and accessories, the warranty period is 90 (ninety) days.

PRODUCT SPECIFICATIONS: Published specifications whether contained herein or in any other materials or documents distributed to Buyer by Novus do not become final or binding on NOVUS until approved by NOVUS. NOVUS expressly reserves the right to change or modify specifications at any time without prior notice.

 <hr/>	User Manual	NP3001-OG
	Revision #:	G
	Date:	11-14-17

WARRANTY LIMITATIONS: NOVUS MAKES NO OTHER WARRANTY, EITHER EXPRESSED OR IMPLIED, WITH RESPECT TO THIS PRODUCT. NOVUS SPECIFICALLY DISCLAIMS THE IMPLIED WARRANTIES OF MERCHANTABILITY OR FITNESS FOR A PARTICULAR PURPOSE.

IN ALL CIRCUMSTANCES NOVUS' MAXIMUM LIABILITY IS LIMITED TO THE PURCHASE PRICE OF THE PRODUCTS SOLD. NOVUS SHALL NOT, UNDER ANY CIRCUMSTANCES BE LIABLE UPON A CLAIM OR ACTION IN CONTRACT, TORT, INDEMNITY OR CONTRIBUTION OR OTHER CLAIMS RELATING TO THE PRODUCTS IT SELLS WHICH EXCEEDS THIS LIABILITY LIMIT. NOVUS SHALL NOT BE LIABLE FOR THIRD PARTY CLAIMS FOR DAMAGES AGAINST THE CUSTOMER, OR FOR MALFUNCTION, DELAYS, INTERRUPTION OF SERVICE, LOSS OF BUSINESS, LOSS OR DAMAGE TO EXEMPLARY DAMAGES, WHETHER OR NOT NOVUS HAS BEEN MADE AWARE OF THE POSSIBILITY OF SUCH CLAIMS OR DAMAGES.

LIMITATION OF REMEDIES: REGARDLESS OF WHETHER ANY REMEDY SET FORTH HEREIN FAILS OF ITS ESSENTIAL PURPOSE, IN NO EVENT WILL NOVUS BE LIABLE TO YOU FOR ANY SPECIAL, CONSEQUENTIAL, INDIRECT OR SIMILAR DAMAGES, INCLUDING, WITHOUT LIMITATION, DAMAGES FOR LOSS OF BUSINESS PROFITS, BUSINESS INTERRUPTION, LOSS OF DATA OR BUSINESS INFORMATION (OR OTHER PECUNIARY LOSS) ARISING OUT OF THE USE OF OR INABILITY TO USE THE HARDWARE SUPPLIED THEREWITH EVEN IF NOVUS OR ANYONE ELSE HAS BEEN ADVISED OF THE POSSIBILITY OF SUCH DAMAGES, OR FOR ANY CLAIM BY ANY OTHER PARTY. EXCLUDED DAMAGES SHALL INCLUDE, BUT ARE NOT LIMITED TO: COSTS OF REMOVAL AND INSTALLATION, LOSSES SUSTAINED AS THE RESULT OF INJURY TO ANY PERSON, OR DAMAGE TO PROPERTY.

EXCLUSIVE REMEDIES: THE REMEDIES PROVIDED HEREIN ARE THE CUSTOMERS' SOLE AND EXCLUSIVE REMEDIES. IN NO EVENT SHALL NOVUS BE LIABLE FOR ANY DIRECT, INDIRECT, SPECIAL, INCIDENTAL, OR CONNSEQUENTIAL DAMAGES, WHETHER BASED ON CONTRACT, TORT, OR ANY OTHER LEGAL THEORY.