

# PA17

## Power Adapter, 12 Vdc, 1 Amp

### KEY FEATURES

Low noise 12 Watt, 12Vdc power adapter selected to operate a range of Novus references, distribution amplifiers and related products. Unit will operate from 90 to 264Vac, 47/63 Hz sources. Hiccup short circuit protection prevents overheating. Fused at 1 Amps. Less than 200 mV of ripple. The unit is shipped with the connector compatible with the product to be powered. International plug adapter set available.

### Product Highlights

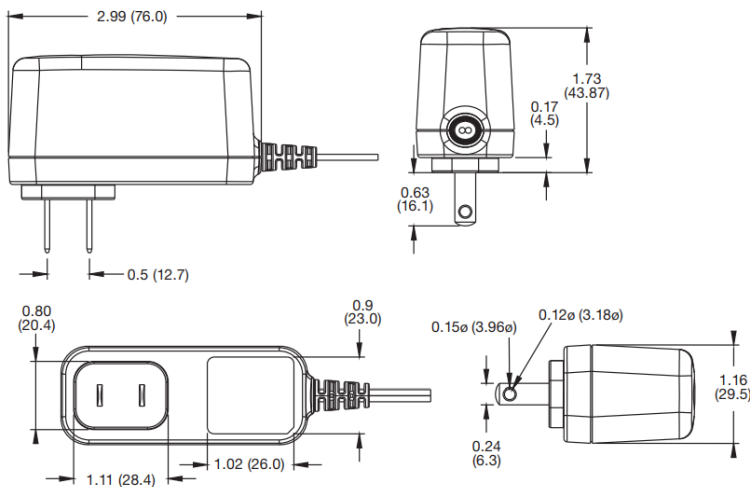

### International Power

Operates from 90 to 264 Vac 47-63 Hz. International plug set available.

### Low Noise- 200 mV

### Short Circuit Protected

## Technical Specifications

---

Input	90 to 264 VAC 47 to 63 Hz
Output	12 Vdc @ 1 Amp
Total Regulation	±5 %
No Load Power	< 0.1 W
Safety Standards	CB Report, CCC, TUV, UL
Cable Length	1.5 meter
Operating Temperature	0 to 60°C
Altitude	5000 meters
Humidity	5 to 95% non-condensing
Connectors	
Output	Variable – selected to match load
Input	International plug kit available
MTBF	>100,000 hrs

This document is copyright © December 2, 2020 Novus Power Products LLC. All rights reserved. This document is provided for information purposes only; contents are subject to change without notice. It is not warranted to be error-free, nor subject to any other warranties or conditions including implied warranties and conditions of merchantability or fitness for a particular purpose.